

API 6D CHECK VALVE

Full opening swing check valve

FEATURES & STANDARDS

- Industry leading warranty (48/24 months*)
- Firesafe design (ISO 10497)
- Standard valves meet NACE MR0175 & ISO 15156
- In-line repairable & full-port piggable
- Full stainless steel seat with replaceable O-ring
- Forged steel disc (cast for sizes >4") with 316 overlay on sealing area
- Dovetail seat seal groove
- Bleed Plug on cover; and boss provided for drain plug
- Support feet on 6" and larger & lifting eye bolts on 4" and larger
- Suitable for horizontal and vertical (flow-up) installation.
- Standard document package BS/EN 10204-3.1
- All O-rings are AED (anti-explosive decompression design)
- Independent dual cover seals (non-pressure seal design)
- Pressure seal cover standard for larger/high pressure valves (10" and larger ASME 1500 & 8" and larger ASME 2500)
- General standards include: API 6D, CSA Z245.15-13, ASME B16.34

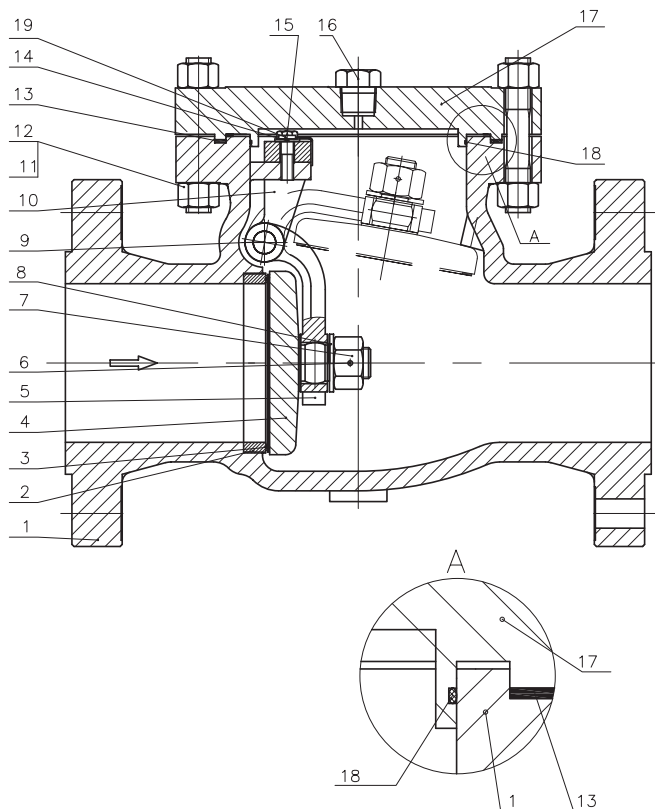
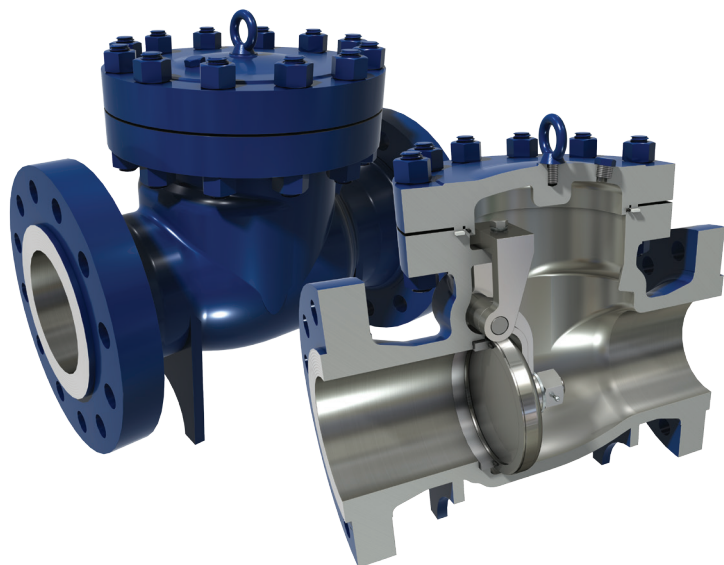

MANUFACTURING RANGE

(Available in full and regular port)

Size	150 ASME PN 20	300 ASME PN 50	600 ASME PN 100	900 ASME PN 150	1500 ASME PN 250	2500 ASME PN 420
2						
3	•	•	•	•	•	•
4	•	•	•	•	•	•
6	•	•	•	•	•	•
8	•	•	•	•	•	•
10	•	•	•	•	•	•
12	•	•	•	•	•	•
14	•	•	•	•	•	•
16	•	•	•	•	•	•
18	•	•	•	•	•	•
20	•	•	•	•	•	•
24	•	•	•	•	•	•
30	•	•	•	•	•	•
36	•	•	•	•	•	•
40	•	•	•	•	•	•
42	•	•	•	•	•	•
48	•	•	•	•	•	•
50	•	•	•	•	•	•
54	•	•	•	•	•	•
56	•	•	•	•	•	•
60	•	•	•	•	•	•

“•” denotes standard design.

“◦” denotes larger sizes that are available on request

ITEM	DESCRIPTIONS	ITEM	DESCRIPTIONS	ITEM	DESCRIPTIONS
1	BODY	8	WASHER	14	SPRING WASHER
2	SEAT	9	HINGE PIN	15	ROCKER ARM HANGER BOLT
3	SEAT O-RING	10	ROCKER ARM HANGER	16	PLUG (NPT)
4	DISC	11	NUT	17	COVER
5	ROCKER ARM	12	STUD	18	O-RING
6	COTTER PIN	13	SPIRAL WOUND GASKET	19	ANTI-ROTATION DEVICE
7	NUT				

NOTES: Drawings are representative. Please contact Meridian for specific and current PDF drawings.
* Meridian™'s limited warranty of 48 months from date of shipment or 24 months from date of start-up.